

# WPL9060 Weigh Price Labeller

Precision weighing and labelling at speeds up to 60 packs/min.

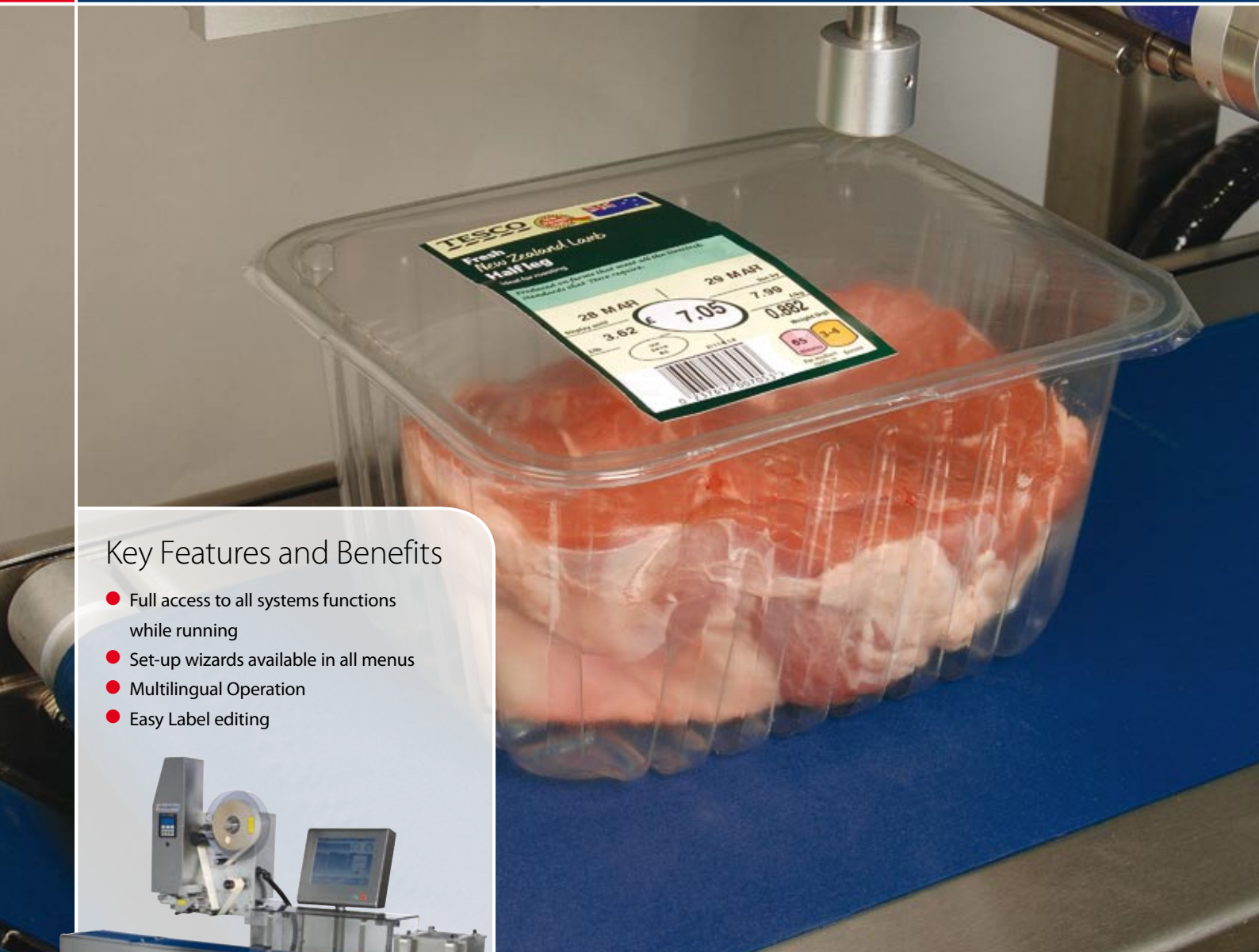

## Key Features and Benefits

- Full access to all systems functions while running
- Set-up wizards available in all menus
- Multilingual Operation
- Easy Label editing



# WPL9060 Weigh Price Labeller

The AEW Delford **WPL9060** represents a new generation of reliable, accurate, easy to use, time saving weigh price labellers that can operate for long periods without interruption. It employs the very latest technology and class leading design to provide excellent performance at a competitive price. **WPL9060** is designed for a wide range of applications and industries and handles all popular tray sizes at up to 60packs/min.

## Key Features and Benefits

- **Full access to all systems functions while running**  
No need to stop machine to check next label set-up or prepare for new product. Saves huge amount of time between label changes.
- **Set-up wizards available in all menus**  
Wizards guide the operator through machine and label set-ups reducing need to learn each step when configuring. Easier and less training.
- **Multilingual Operation**  
Language module enables operation in a number of key languages. Each user has a password protected favourites folder providing quick and easy access to their own commonly used menus. All changes are logged and traced back to user.
- **Easy Label editing**  
What you see on the screen is what you get on the label. Background label image can be stored on the WPL.  
Drag and drop touch screen facility positions print on label and label position on pack.
- **Touch Screen Control**  
Wizards guide the operator through machine and label set-ups reducing need to learn each step when configuring. Easier and less training.
- **Digital weighing accuracy, precision and reliability**
- **System Logging**  
Files can be transferred to and from WPL 9060 using Windows Explorer. All data is logged in a SQL database and pack/label information is date and time stamped then stored, enabling a high level of integration.
- **Production Control**  
WPL 9060 can be integrated with Innova, Marel Food Systems revolutionary software that controls and monitors each step of production in one integrated system software.

## Technical Information

**Power requirement:** 110/230V +/-10%, 50-60Hz, 1 phase

**Compressed air:** 100 l/min @ 6 bar

### Pack Sizes:

(mm)	length	width	height
Minimum	80	60	6
Maximum	350	240	150

### Weight ranges:

Metric	40g to 4.6kg x 2g Increments
Cental	0.20lb to 10lb x 0.01lb Increments

### Enhanced dual metric ranges:

20g to 1.5kg x 1g/1.5kg to 4.6kg x 2g, 40g to 5.5kg x 2g

Accuracy performance to OIML Class III(1),Y(a)

### Optional features

Integral automatic twin belt infeed

Price switching and/or label operation controlled by weight zones

Multi-level totalisation of quantity, weight and price

Increased pack height on request

Increased weight ranges on request

Additional labelling heads

AEW Delford Systems machines carry CE certification.

The **WPL9060 Weigh Price Labeller** can operate as a stand alone machine or it can be integrated with a range of manual or automatic production lines and Innova, Marel Food Systems intelligent production control software.

For further information please logon to: [www.aewdelford.com](http://www.aewdelford.com)

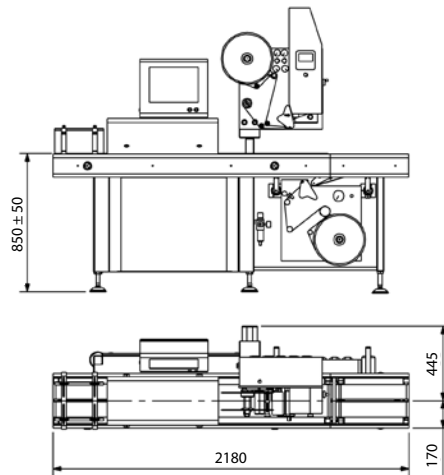

RETURN ON INNOVATION

**marel**  
food systems