

TL620 Print & Apply Labeller

Flexible in-line top labelling



Key Features and Benefits

- Variable and pre-printed labelling capability for maximum flexibility.
- Multiple label applicators.
- Choice of speeds – 60 or 200 packs/min.
- High resolution – 12dot/mm printing.
- Available as free standing system or modular unit.
- Direct chemi-thermal or thermal transfer print options.
- Fully programmable – up to 1000 label formats.
- Off-line graphic software and formatting.
- Label rotation facility.



TL620 Print & Apply Labeller

AEW Delford Systems wide range of Weigh Price Labellers and label applicators includes the **TL 620 Print and Apply Labeller** – an efficient means of providing flexible, high quality in-line labelling.

Ideal for food applications, such as bakery, meat and ready meals, where a varying range of packaged products requires ever-changing label information, the **TL620** can be configured to suit individual customer needs.

The system is available in two models – 60 packs/min and 200 packs/min – subject to label size and print requirements.

Labelling heads can be conveyor-mounted or free-standing with top labelling or under labelling options, applying multiple labels to each pack with a mix of pre-printing and variable-printing functions.

Label print quality is excellent, with 12 dot/mm resolution direct chemi-thermal or thermal transfer printing technology. All recognised barcode configurations can be printed and comprehensive off-line graphic software allows special logos and bitmap images to be incorporated into labels.

The **TL620** is fully programmable and easy to use, with a 1000 label comformat memory accessed via an integral keypad with visual display interface. It can be operated to stand-alone via a floppy disk interface or networked by remote RS232 or RS485 connection.

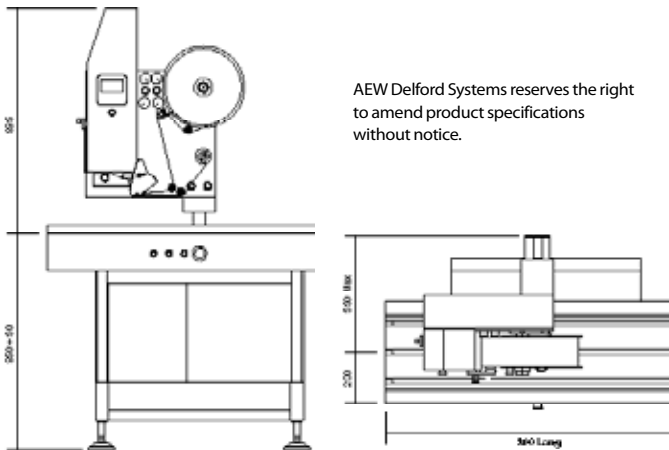

Subject to change without notice: TL620/KIG/9.08

Technical Information

Labelling

High resolution printing via 12 dot/mm print head

Extensive independent label fields

Full EAN barcode capability

Wide range of character font styles

300mm capacity label reel

Minimum label size: 30mm x 30mm

Maximum label size: 110mm wide x 150mm long
subject to model, throughput speed and printing

Rotating applicator by comformat

General

60 or 200 ppm subject to selected label size and model

Left or right hand models

Free standing or conveyor mounted

Ability to download via floppy disk or RS232 connection.

Unlimited graphic and character printing through the use of bitmaps

Services

230/110V +/- 10%

1 phase 50-60Hz

Compressed air: 100 l/min @ 6 bar

Up to 1000 label comformats can be accessed or edited via the integral keypad.



RETURN ON INNOVATION

marel
food systems