

Junior Slicer



Features and Benefits

- Up to 200 product programmes means fast product changeover.
- All product contact parts are easily removed for fast and thorough cleaning.
- Orbital blade for accurate slicing of delicate products.
- Patented twin jump conveyor option for high speed transfer of sliced groups.
- Fully adjustable jump conveyor for shingle lengths of up to 250mm and stacking heights of up to 75mm.
- Interleaver option for inserting paper or film into products like cheese and cured meats.
- Automatic product gripper optional.
- Robust stainless steel construction.

aew delford
systems

AEW Delford Systems **Junior Slicer** is intended for the user who requires a compact, easy to use machine.

The **Junior** will produce well defined stacks, shingles or shaved products at speeds up to 600 rev/min. It is flexible enough to slice a very wide range of cooked meats, bacon and natural products. It will also slice more fragile products including cheese.

Checkweigher feed back for accurate fixed weight is an option.

The **Junior Slicer** has been designed and engineered for low maintenance and a high level of reliability.

As with all AEW Delford Systems slicers, the **Junior Slicer** is of robust stainless steel construction and has full CE certification.

Integrated Systems

Junior Slicer can operate as a stand alone machine or it can be integrated with a range of manual, fixed or random weight production lines.

For further information please logon to:
www.aewdelford.com



Junior Slicer

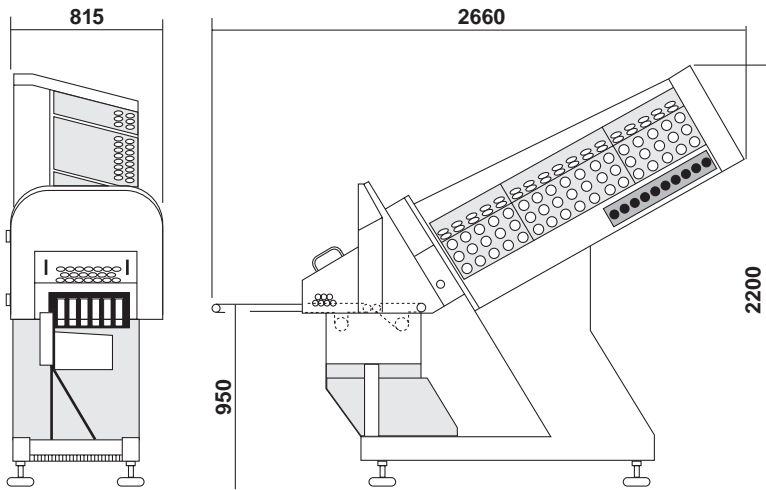

Technical Information

Speed: Up to 600 rev/min

Slice Thickness: 0.6–9.9mm

Blade: Orbital

Pack Presentation: Shingled, Stacked, Shaved

Product Programmes: 200

Jump Conveyor:

Single, double or extended strip belt 1000mm

Electrical Supply:

380–415V ± 10% + 3 Phase

50/60 Hz @ 11kVA

Air Supply: 0.5 l/min @ 5 bar

Product Lengths:

Up to 900mm or up to 1000mm

Throat Size: 135mm high x 240mm wide
and 150mm diameter

Net Weight: 750 Kg

Distributor

AEW THURNE Ltd
Pinetrees Road, Norwich
NR7 9BB, UK

Tel: +44 (0) 1603 700755
Fax: +44 (0) 1603 700844

E-mail:
norwich@aewdelford.com

AEW THURNE Inc.
1148 Ensell Road,
Lake Zurich, IL 60047, USA

Tel: 847 726 8000
Fax: 847 726 1600

E-mail:
chicago@aewdelford.com

www.aewdelford.com