

# C3 Panel Label Applicator



## Key Features and Benefits

- High speed applicator for maximum label length
- Driven side belts for optimum pack retention
- Quick and easy label change
- Up stream communication to optional weigh device
- Labelling speeds up to 80 packs per minute
- Repeatable and consistent label accuracy



# C3 Panel Label Applicator

The AEW Delford Systems **C3 Panel Label Applicator** can position and apply a self-adhesive label around three sides of a rigid package.

Powerful servo driven motors enable a label of up to 390mm in length to be issued and applied with repeatable and consistent accuracy.

The applicator is mounted on a purpose designed 1.3m conveyor onto which driven side belts are fitted to ensure the pack is held securely while the unique mechanism wraps the label round the pack.

An optional integral ribbon printer will accept commands from an upstream weigh unit for printing the label with variable or fixed information.

Typical applications include tray seal packs for red meat and poultry.

The **C3 Panel Label Applicator** can be interfaced to upstream weighing units.

Where conventional labelling of packs is required, a Delford 8000 Weigh Price Labelling system can be incorporated into the line. When the **C3 applicator** is switched off, the Weigh Price Labeller can apply labels conventionally.

The Delford 8000 Weigh Price Labeller can be configured to use the **C3 Panel Label Applicator** or on its own conventional labeller as required.

Where conventional labelling is not required, a Delford weighing system can be interfaced to the applicator. The system can then operate as a Weigh Price Labeller or Checkweigher and use the **C3** to issue a printed label with per-pack variable information.

## Technical Information

**Max. label length:** Up to 390mm\*

**Max. label width:** 125mm

**Min. label width:** 65mm

**Max. pack width:** 340mm wide machine:  
269mm narrow machine

**Min. pack width:** 140mm wide machine:  
127mm narrow machine

**Max pack height:** 120mm

**Conveyor speed:** Up to 42m/min

**Electrical supply:** 110/240v 1 phase 60/50 Hz

**Label reel:** Outside or inside wound (outside preferred)  
65-80mm wide: 300mm diameter max  
80-100mm wide: 250mm diameter max  
100-125mm wide: 220mm diameter max

**Core:** 76mm diameter

**Air required:** 6.5 litres/min @ 6 bar max  
(vacuum and air blow system)

\* Subject to label design

### Printing Option 1

Thermal Transfer area 70mm long x 53mm across label.

### Printing Option 2

Thermal Transfer area 70mm long x 100mm across label.

Download via PC/laptop.

Note: Catch weight information can be supplied from upstream Weigh Price unit at extra cost.

Right: C3 interfaced with a Delford 8060 weigh price labeller

Far right: C3 interfaced with an integral weigher

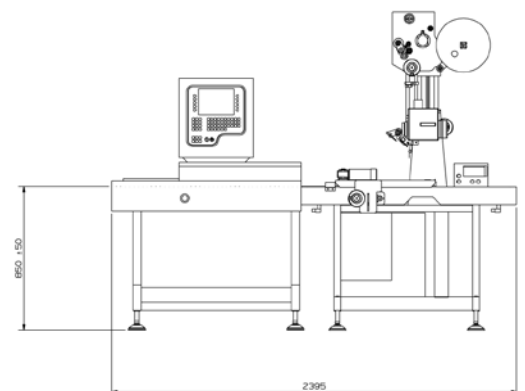
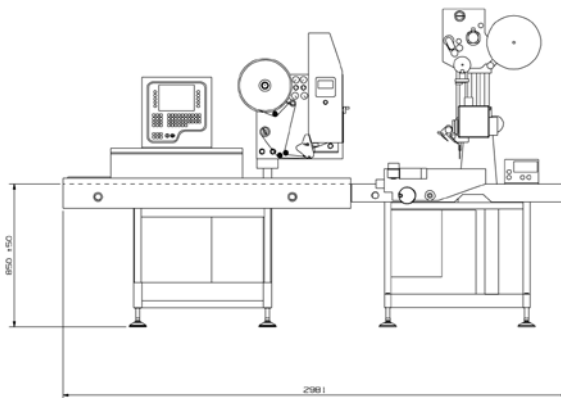

Subject to change without notice /LS40/KIG/9.08

RETURN ON INNOVATION

**marel**  
food systems