

WPL8060 Weigh Price Labeller

Precision weighing and labelling at speeds up to 60 packs/min.



Key Features and Benefits

- Up to 60 packs/min.
- Adjustable infeed guides.
- Stainless steel construction.
- Programmable/rotating label applicator.
- Robust construction.
- Exceptional reliability.
- Choice of right or left hand versions.
- Option of real-time or periodic output facilities via RS232C, RS422, RS485.



WPL8060 Weigh Price Labeller

AEW Delford Systems has combined the latest software technology with class leading design and manufacture, to develop the **WPL8060 Series**.

WPL8060 offers more benefits at a competitive price, with excellent performance and added value. It covers a wide range of applications and industries and includes many new features, such as enhanced software to ease machine programming.

WPL8060 operates at up to 60 packs/min and handles all popular tray sizes, making it suitable for a wide range of packaging applications.

Key Features and Benefits (continued)

Weighing

- Purpose designed dynamic weighing system.
- Switchable weight ranges.

Enhanced dual metric ranges:

- 20g to 1.5kg x 1g/1.5kg to 4.6kg x 2g, 40g to 5.5kg x 2g.
- Accuracy performance to OIML Class III.
- Automatic drift-free zero sequencing.
- Auto-tare facility.

Pricing

- 7 figure pricing selectable by conformat.
- Variable price rounding to suit territory.
- Discount pricing facility.

Labelling

- High resolution printing with 12 dot/mm head.
- Complete label layout flexibility.
- Extensive independent label fields.
- Maximum label size 150mm x 110mm.
- Full EAN and other current barcode types.
- Wide range of character font styles (to 18.3mm).
- Up to 1000 label conformat memory.
- Non-contact, height adjustable label application.
- Large (300mm dia.) capacity label reel for long production runs.
- Direct chemi-thermal or thermal transfer print options.

Technical Information

Power requirement: 110/230V +/-10%, 50-60Hz, 1 phase

Compressed air: 100 l/min @ 6 bar

Pack Sizes:

(mm)	length	width	height
Minimum	80	60	6
Maximum	350	240	150

Weight ranges:

Metric	40g to 4.6kg x 2g Increments
Cental	0.20lb to 10lb x 0.01lb Increments

Optional features

Integral automatic twin belt infeed

Price switching and/or label operation controlled by weight zones

Multi-level totalisation of quantity, weight and price

Up to 1,000 label conformats in on-board memory

Increased pack height on request

Increased weight ranges on request

Additional labelling heads

AEW Delford Systems machines carry CE certification.

The **WPL8060 Weigh Price Labeller** can operate as a stand alone machine or it can be integrated with a range of manual or automatic production lines.

For further information please logon to: www.aewdelford.com

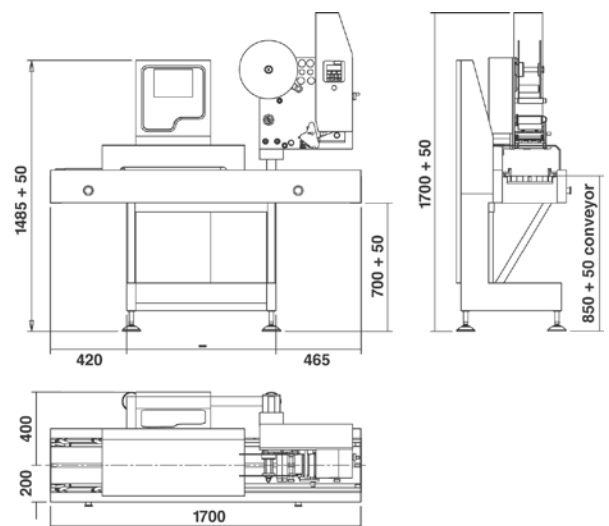

RETURN ON INNOVATION

marel
food systems